

LevelOne

DVI Broadcaster Series

ADE-8001

ADE-8002

ADE-8011

ADE-8201

ADE-8202

ADE-8204

ADE-8208

User Manual

Version 1.0-0611

Introduction

Thank you for purchasing LevelOne DVI broadcaster series products. This DVI broadcaster extends your DVI-D and audio signal over Cat5/5e/6 and 4-wire phone cable. If you are using short range receiver (ADE-8001) to receive the DVI-D signal, the extended distance is up to 15m with 1024x768 resolution; and if using long range receiver (ADE-8002), the extended DVI-D distance can reach the distance up to 70m with 1024x768 resolution. You can use the audio receiver to extend audio over 4-wire phone cable to provide a multimedia broadcasting.

Take the advantage of Cat5/5e/6 cable, LevelOne DVI broadcaster series can simplify the installation, extend the AV signal, and centralize the multimedia server. Many nice features have been designed into these units, the single-port transmitter (ADE-8201) is the smallest one in the world and can connect to DVI port without using another DVI cable. For single port receiver (ADE-8002), you can fix the unit very easily through its magnetic pad and metal plate. The multi-port unit(ADE-8202/8204/8208) is the first multi-port DVI extender over Cat5/5e/6, it allows you to extend DVI signals with reasonable cost and easy installation.

LevelOne DVI broadcaster series is the perfect solution for malls, plazas, stations and supermarkets to display high resolution and crystallized images. It's easy to maintain and reduce installation cost.

Key Features

1. Multiply one DVI-D and audio source to 2/4/8 DVI-D and audio outputs over Cat5/5e/6 and 4-wire phone cable.
2. Video Amplifier Bandwidth: 1.65GHz
3. Effective DVI-D extended distance and resolution for multi-port DVI Broadcaster:
 - DVI Input: transmitting over standard DVI cable up to 10 meters
 - DVI Output: transmitting over standard DVI cable, DVI resolution 1920x1200@10m.
 - RJ45 Output with ADE-8001: transmitting over Cat5/5e/6 cable, maximum DVI resolution 800x600@20m, 1024x768@15m, 1280x1024@10m
 - RJ45 Output with ADE-8002: transmitting over Cat5/5e/6 cable, maximum DVI resolution 800x600@80m, 1024x768@70m, 1280x1024@60m, 1920x1200@35m
4. DVI Input/Output Connector: Type DVI-I, supports only DVI-D digital video signal
5. Audio type and distance: Stereo can be transmitted over 4-wire phone cable over 100 meters. (Audio function not included in ADE-8201, so you will need to purchase a pair of ADE-8011 to extend the audio source.)
6. Input for one DVI-D + audio, output for one DVI-D + audio connection and 1/2/4/8 sets of RJ-45 and RJ-11 connections to transmit DVI-D and audio signal using Cat5/5e/6 and 4-wire phone cable. (Audio function not included in ADE-8201)
7. RJ-45 to DVI-D receiver (ADE-8001 or ADE-8002) to receive the DVI-D signal from Cat5/5e/6 cable, and RJ-11 Audio Transmitter/Receiver (ADE-8011) to receive the audio signal from 4-wire phone cable (Audio function not included in ADE-8201)
8. Transmitter builds in DVI monitor's EDID simulation, computer can boot up DVI signal without connecting local monitor, initial pre-set range of frequency up to 1920x1200
9. LED status to indicate the DVI activity
10. Stackable capacity to expand the AV broadcasting
11. Provides magnetic pad and attachable metal plate for ADE-8002 to ease the installation

Panel Description

1. ADE-8201 1-Port DVI Transmitter

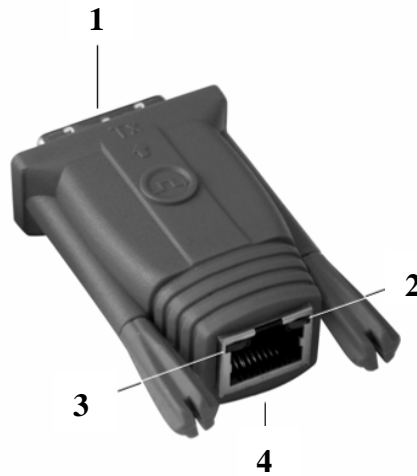

1. Connect to PC's DVI Port
2. Power indicator (Orange LED)
3. Active (Green LED)
4. RJ-45 DVI-D output

2. ADE-8202 2-Port DVI Broadcaster with Audio



Active : DDC2B activity

Local Monitor : link of local monitor

Power : Power Indicator

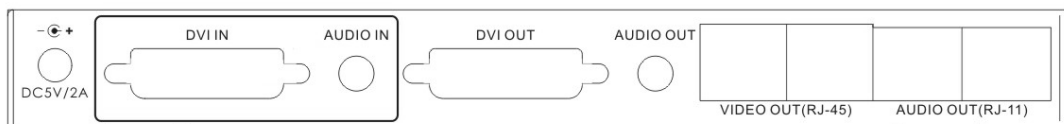

Power Jack : Connect to power adapter

DVI/AUDIO IN : Connect to DVI and audio source

DVI/AUDIO OUT : Connect to local monitor and speaker

VIDEO OUT : RJ-45 DVI output

AUDIO OUT : RJ-11 Audio output

3. **ADE-8204** 4-Port DVI Broadcaster with Audio

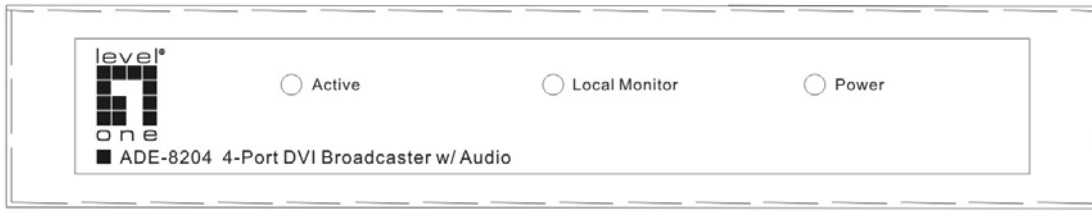

Active : DDC2B activity

Local Monitor : link of local monitor

Power : Power Indicator

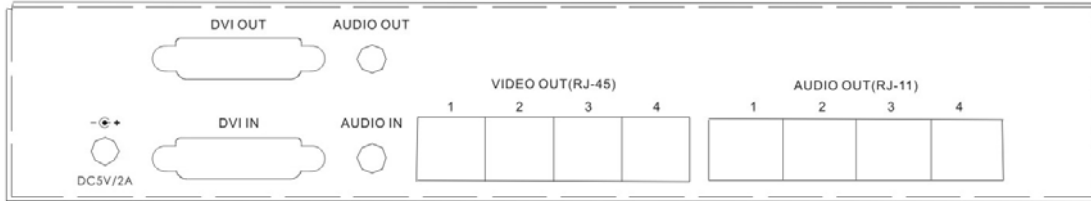

Power Jack : Connect to power adapter

DVI/AUDIO IN : Connect to DVI and audio source

DVI/AUDIO OUT : Connect to local monitor and speaker

VIDEO OUT : RJ-45 DVI output

AUDIO OUT : RJ-11 Audio output

4. **ADE-8208** 8-Port DVI Broadcaster with Audio

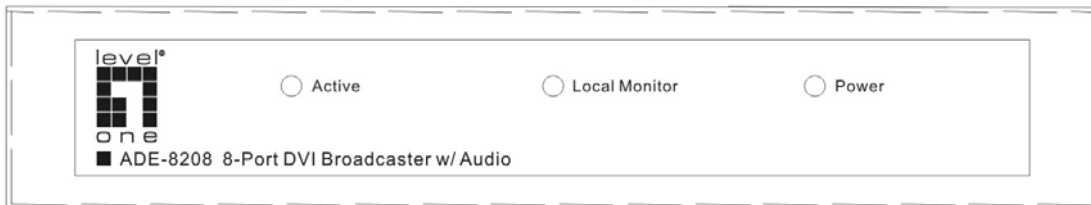

Active : DDC2B activity

Local Monitor : link of local monitor

Power : Power Indicator

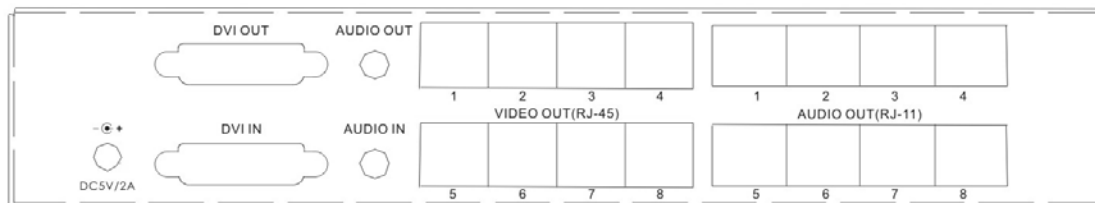

Power Jack : Connect to power adapter

DVI/AUDIO IN : Connect to DVI and audio source

DVI/AUDIO OUT : Connect to local monitor and speaker

VIDEO OUT : RJ-45 DVI output

AUDIO OUT : RJ-11 Audio output

5. **ADE-8001** DVI-D Short Range Receiver



1. DVI output (To monitor)
2. RJ-45 DVI input

6. **ADE-8002** DVI-D Long Range Receiver

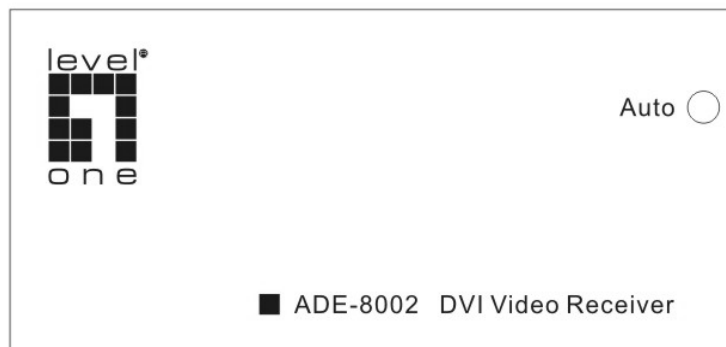

Auto : Auto EQ is selected

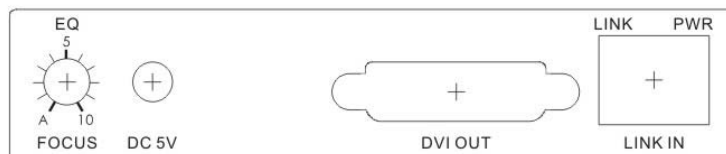

FOCUS : EQ adjust (Auto or manual)

Power Jack : Connect to power adapter

DVI OUT : Connect to monitor or projector

LINK LED : DVI activity

PWR LED : Power indicator

LINK IN : RJ-45 DVI input

7. **ADE-8011** Audio Transmitter/Receiver



1. Connect to audio jack
2. RJ-11 audio input/output

Installation and Operation

1. Install Single-Port Transmitter ADE-8201 and DVI Signal Receiver ADE-8001/8002:

- (1) Basic Function Test: In the beginning, please connect your DVI monitor to your PC or DVI player to confirm the basic display function and remain these devices turned on for next installation sequence.
- (2) Install Single-Port Transmitter ADE-8201: Please connect ADE-8201 to your PC or DVI player's DVI output port while the device is turned ON, the LED of ADE-8201 should all turn ON, the orange LED indicates the power ON status and the green LED indicates the DDC2B activity of DVI port. Please notice that the ADE-8201 has pre-set an EDID with a maximum DVI supporting frequency of 1920x1200 and can simulate the behavior of DVI monitor, so the PC's DVI port will remain activate even when you re-boot the PC without plug actual DVI monitor.



Connect ADE-8201 to PC

- (3) Install ADE-8001: Please connect ADE-8001 to your DVI display device's DVI port directly. The DVI monitor can be PDP, LCD TV, projector or LCD. The supported DVI resolutions are 800x600@20m, 1024x768@15m, 1280x1024@10m.



DVI Projector and Monitor



Short Range Receiver

Connect Short Range Receiver ADE-8001 to DVI Monitor

(4) Install ADE-8002:

- A. Plug power adaptor to ADE-8002, the orange LED above RJ-45 should be ON to indicate the power on status. The other LED should turn off, since there is no input of video signal from "LINK IN" port.
- B. The "Auto" led in the front panel will turn ON as the EQ/FOCUS control switch to the left end and the EQ/FOCUS will stay on AUTO, this will not function until the receiver received video signal from "LINK IN" port.
- C. Connect DVI monitor's DVI cable to the receiver.



Connect ADE-8002 to DVI Monitor by DVI Cable

- (5) Selection of Cat5/5e/6 cable: You may use most of current Cat5/5e/6 cables, and since the quality varies, we do encounter some cables not perform well, even it is expensive. Therefore, please test your current cables before you install the devices on the site. For some environment need to prevent potential interference, the FTP type cable is recommended. The connector must be made by 568B-568B type. The EIA/TIA definition of 568B in the pin assignment is (1)orange white, (2)orange, (3)green white, (4)blue, (5)blue white, (6)green, (7)brown white, and (8)brown.

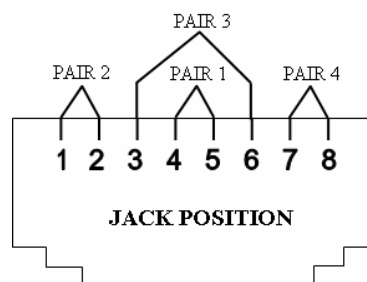

- (6) Connect Cat5/5e/6 cable: Plug two ends of cable to Transmitter and Receiver's RJ-45 port, the monitor connected to the Receiver should display now and the green LED above ADE-8002's RJ-45 port should be ON to reflect the DVI signal activation. For ADE-8002, you can manually adjust the EQ/FOCUS to have the best display quality. The displayed DVI resolution will also relate to the distance been extended, it will be better to test prior actual installation and should not exceed the suggested frequency and corresponding distance.

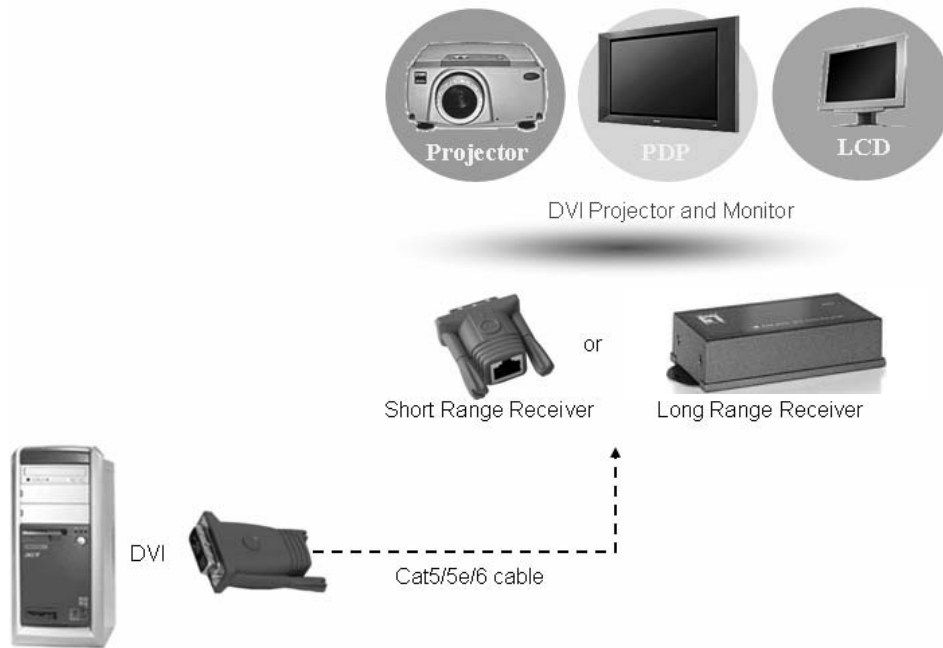

Connection of Single-Port DVI-D Extender

- (7) Extends Audio Signal: There is no audio function on ADE-8201, so you need to use a pair of ADE-8011 to extend the audio and the cable using is 4-wire phone cable and two ends of the cable should be made by straight RJ-11 connector.

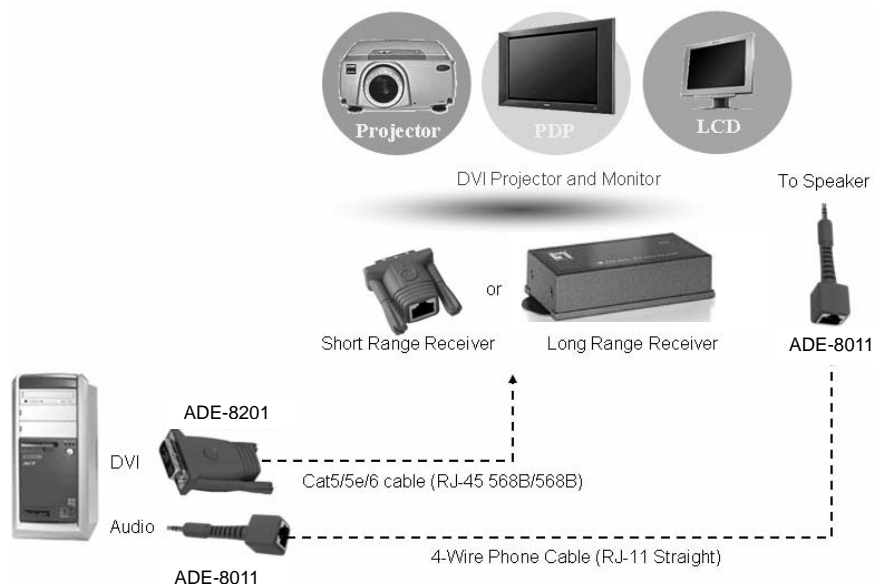

Extended Connection of DVI-D with Audio

2. Install Multi-Port Transmitter:

- (1) The 2/4/8-port model will all act the same except they have different amount of outputs.
- (2) First Time Set-up: Please turn off the DVI output device (PC or DVD Player) and monitors.
- (3) Connect local DVI monitor and speaker to the “DVI/AUDIO OUT” of the transmitter and plug one end of DVI/Audio cable to “DVI/Audio IN” port of transmitter and the other end of the cable to the output device’s DVI and speaker ports.
- (4) Connect power adaptor.
- (5) Turn on your DVI output device and monitor to confirm the function of display. The “Local Monitor” LED of the transmitter should turn orange to reflect the connection of a local DVI monitor and the “ACTIVE” LED should turn blue to indicate an activated DVI-D signal.
- (6) The transmitter has built in an EDID simulator, when you connect local DVI monitor, the transmitter will automatically record the EDID from DVI monitor. When the local DVI monitor is not connected, the transmitter will simulate the EDID communication like a regular monitor and activate the DVI signal of PC.

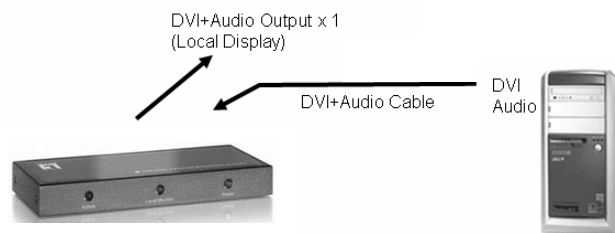

Local Connection of Multi-Port Transmitter

3. To connect remote monitors and speakers through RJ-45 and RJ-11 ports:

- (1) You can refer to previous section for Receiver to install and prepare the cable to be connected.
- (2) RJ-45 VIDEO with ADE-8001: The RJ-45 ports in the back of Transmitter can only support DVI-D signal. For each connector, please prepare one Cat5/5e/6 cable and make the cable as 568B-568B type [more details about Cat5/5e/6 cable, please refer to previous section of 1. (3) ~ (6)], and plug one end of the cable to the RJ-45 port of ADE-8201/8202/8204/8208 and the other end to the RJ-45 port of ADE-8001 and connect ADE-8001 to the DVI monitor. If the video connection is HDMI type, you will need to use appropriate DVI-HDMI adaptor to connect(The DVI-HDMI adapter is not included in the package). The supported DVI-D resolution and distance is similar to using regular DVI cable, the estimated ranges are: 800x600@20m, 1024x768@15m, 1280x1024@10m. Previous range can be applied in most of the application, but in some cases it might change. It will be appropriate to test the capacity of display before installation.
- (3) RJ-45 VIDEO with Long Range Receiver ADE-8002: Please refer to previous

section 1.(4) ~ (6) to install ADE-8002 and cable. If the video connection is HDMI type, you will need to use appropriate DVI-HDMI adaptor to connect. The supported DVI-D resolution and distance is similar to regular DVI cable, the estimated ranges are: 800x600@80m, 1024x768@70m, 1280x1024@60m, 1920x1200@35m. Previous range can be applied in most of the application, but in some cases it might change. It will be appropriate to test the capacity of display before installation.

- (4) RJ-11 AUDIO: The RJ-11 ports in the back of transmitter(ADE-8202/8204/8208) support stereo audio. Please prepare one 4-wire phone cable or use 4 wires out of the Cat5/5e/6 cable to make the RJ-11 connector. The pin definition of RJ-45 is one to one and the supported length is 100 meters.



Connection of 2-Port Transmitter

Stack More Transmitters to Have More Displays

1. If you would like to broadcast more monitors and speakers, you can connect another layer of same DVI broadcaster series products. You can connect additional Transmitter from “DVI/AUDIO IN” port or “VIDEO OUT and AUDIO OUT” ports:
 - (1) From “DVI/AUDIO OUT”: Use one set of standard DVI/Audio cable, one end connect from the “DVI/AUDIO OUT” port of the first layer’s Transmitter and the other end to “DVI/AUDIO IN” port of the second layer’s Transmitter.
 - (2) From “VIDEO OUT and AUDIO OUT”: Similar to the way of connecting monitor and speaker, you connect ADE-8001 and ADE-8011 to the “DVI/AUDIO IN” port of the second layer’s Transmitter. The length for this extension should be between 10

to 25 meters and the total extended length and resolution is about 800x600@20m, 1024x768@15m, 1280x1024@10m. Previous range can be applied in most of the application, but in some cases it might change. It will be appropriate to test the capacity of display before installation.

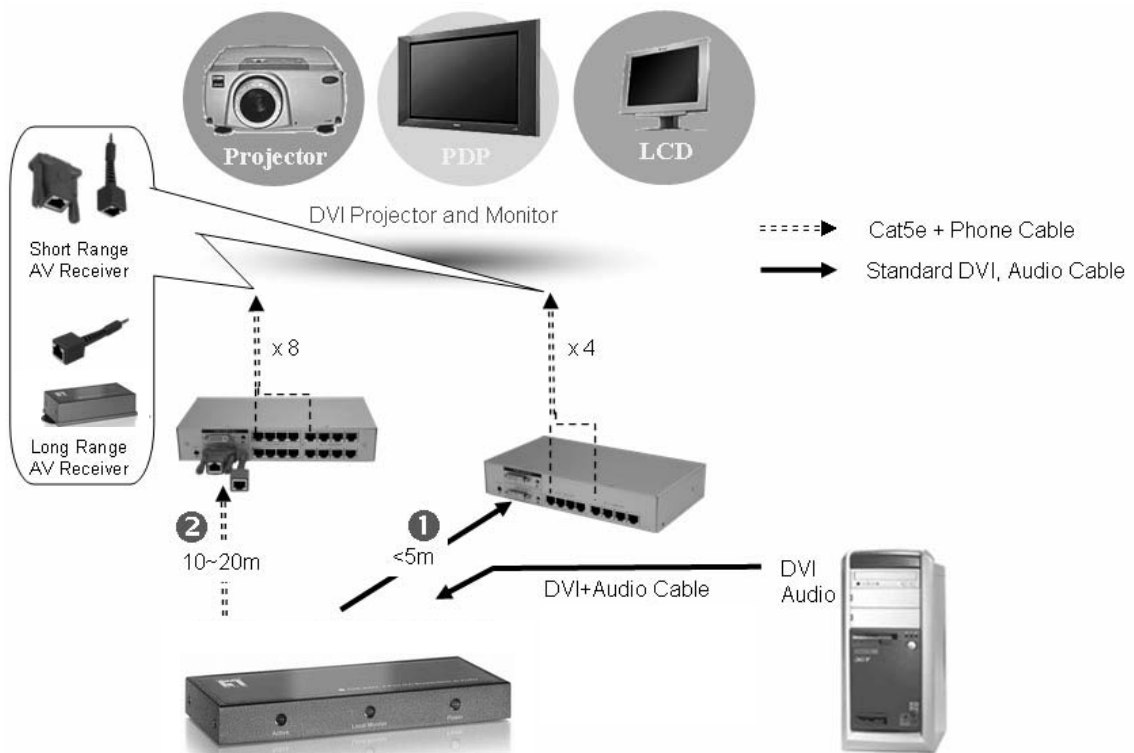

Diagram of Connecting another Layer of Cat5/5e/6 DVI Transmitter

2. To ensure the transmitting quality of DVI-D signal, more than two layer of stacking is not recommended.
3. The transmitter can be 2, 4, or 8 port model.

Specification

Model	ADE-8201	ADE-8202	ADE-8204	ADE-8208
Function	Single-Port DVI Transmitter	2-Port DVI Broadcaster with Audio	4-Port DVI Broadcaster with Audio	8-Port DVI Broadcaster with Audio
Input	DVI Male x 1	DVI Female x 1, Audio x 1		
Output	RJ-45 x 1	DVI Female x 1 Audio x 1 RJ-45 x 2 RJ-11 x 2	DVI Female x 1 Audio x 1 RJ-45 x 4 RJ-11 x 4	DVI Female x 1 Audio x 1 RJ-45 x 8 RJ-11 x 8
RJ-45 to DVI-D Receiver and RJ-11 to Audio Receiver	One RJ-45 to DVI-D Receiver (ADE-8001 or ADE-8002)	2 sets	4 sets	8 sets
Max Distance and Resolution	DVI Input	Transmitting over standard DVI cable up to 10 meters		
	DVI Output	-	Transmitting over standard DVI cable, DVI resolution 1920x1200@10m.	
	RJ45 Output	Transmitting over Cat5/5e/6 cable, DVI resolution for ADE-8001 is 800x600@20m, 1024x768@15m, 1280x1024@10m; for ADE-8002 is 800x600@80m, 1024x768@70m, 1280x1024@60m, 1920x1200@35m		
Signal Type	DVI-D			
Power Consumption	DC 5V, 250mA	DC 5V, 800mA	DC 5V, 1000mA	DC 5V, 1200mA
Housing	Plastic	Metal		
Dimension (LxWxH) mm	Compact	1U Height	1U Height	1U Height

Model	ADE-8001	ADE-8002	ADE-8011	
Function	Short range DVI Receiver	DVI Video Receiver	Audio Transmitter/Receiver	
Input	RJ-45 x 1	RJ-45 x 1	RJ-11 x 1	Audio Jack x 1
Output	DVI Female x 1	DVI Female x 1	Audio Jack x 1	RJ-11 x 1
Max Distance and Resolution	Transmitting over Cat5/5e/6 cable, DVI resolution 800x600@20m, 1024x768@15m, 1280x1024@10m.	Transmitting over Cat5/5e/6 cable, DVI resolution 800x600@80m, 1024x768@70m, 1280x1024@60m, 1920x1200@35m	Transmitting over 4-wire phone cable, stereo audio over 100m	
Signal Type	DVI-D		Stereo	
Power Consumption		DC 9V, 500mA		

Remarks

1. Before operating this splitter, please read operation manual carefully.
2. Please use high quality DVI, audio cable for optimum operation.
3. To prevent potential power damage, please don't use 2-wire extension cord and ensure AC outlets at PCs and monitors are on the same phase and have correct grounding.

