

# DOH-1100

## Heavy-Duty Domed Outdoor Housing

DOH-1100 is a heavy-duty outdoor housing that protects your LevelOne network camera from harsh weather conditions.

**Durable:** Heavy duty aluminium dome for outdoor and indoor installation

**2-layer dome design:** Helps keep the camera cool in hot weather by creating a pocket of air that adds extra insulation.

**Temperature control:** An automatic sensor regulates the dome's temperature, making sure extreme weather conditions do not affect camera viewing or operation. The built-in fan turns on when it is hot, the built-in heater turns on when it is cold. (See temperature information below.)

**New coating:** Fluorocarbon paint resists salt water, as well as other acids and bases.

**Easy to install:** Perfect match with LevelOne FCS-1010, FCS-1040 and FCS-1060, simple internal mounting bracket.



DOH-1100

### Related Products



**FCS-1010**

10/100Mbps P/T IP Network Camera



**FCS-1040**

10/100Mbps P/T/Z IP Network Camera



**FCS-1060**

10/100Mbps P/T/Z IP Network Camera

## Key Features

- Heavy-duty aluminium dome for outdoor and indoor installation
- 2-layer dome design keeps cameras cool
- Special fluorocarbon coating resists harsh acids and bases (i.e. salt water)
- Auto-sensing fan and heater for internal temperature control
- Vandal-proof polycarbonate cover
- IP-66 rated protection level

## Dimension

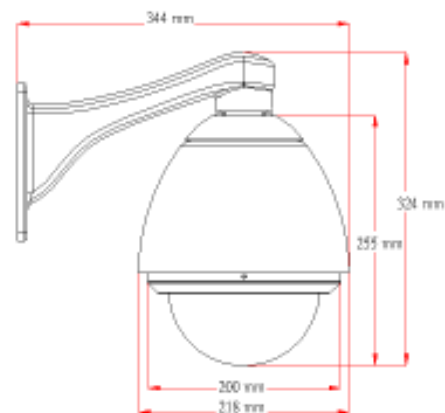

## Technical Specification

- |   |  |
|---|--|
| ▪ <b>Regulation Rated</b><br>IP66       | ▪ <b>Temperature</b><br>Operating: -20°C ~50°C<br>Storage: -40°C ~60°C             |
| ▪ <b>Housing Color</b><br>Beige         | ▪ <b>Humidity</b><br>0%~95% (RH)   |
| ▪ <b>Diameter</b><br>φ 200 mm           | ▪ <b>Heater Operation</b><br>Activates at 4°C (±5°C)<br>Deactivates at 16°C (±5°C) |
| ▪ <b>Cover Color</b><br>Clear           | ▪ <b>Fan Operation</b><br>Activates at 40°C (±5°C)<br>Deactivates at 30°C (±5°C)   |
| ▪ <b>Video Output</b><br>Female BNC     | ▪ <b>Weight</b><br>3.1Kg   |
| ▪ <b>Power Consumption</b><br>12V/ 2.5A |  |
| ▪ <b>Control/Power</b><br>Thermal block |  |

## Ordering Information

- DOH-1100: Heavy-duty Domed Outdoor Housing for FCS-1010/1040/1060

For more information, please contact your LevelOne representative, or visit [www.level1.com](http://www.level1.com)  
All technical specifications are subject to change without notice.  
All mentioned brand names are registered trademarks and property of their owners

